

Workholding bolts

with ball-type shoulder

SPECIFICATION

Types

- Type **B**: Workholding bolt cylindrical
- Type **C**: Workholding bolt flattened

Steel
hardened

INFORMATION

Workholding bolts GN 6322 are used for positioning in bores, with the ball-type shoulder facilitating the insertion into the bore. The flattened design (Form C) helps to compensate tolerances in the spacing of two bores. Another application of this design is to fix parts to be positioned in one direction only.

TECHNICAL INFORMATION

- ISO-Fundamental Tolerances (see page A21)

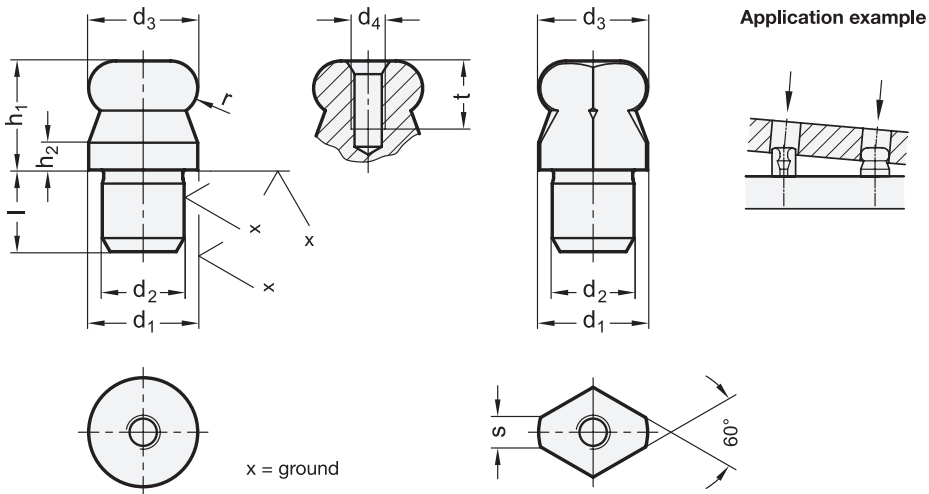

GN 6322

Description	d1 g6	d2 n6	d3 -0.01/-0.05	d4	h1	h2	l	s	t	r	⚖
GN 6322-10-7-B	10	7	10	M3	10	2.5	7	-	6	2.5	7
GN 6322-12-8-B	12	8	12	M4	12	3	8	-	8	3	11
GN 6322-16-12-B	16	12	16	M5	16	4	12	-	10	4	30
GN 6322-20-14-B	20	14	20	M5	20	5	14	-	10	5	57
GN 6322-22-16-B	22	16	22	M5	22	5.5	16	-	10	5.5	79
GN 6322-25-18-B	25	18	25	M5	25	6	18	-	10	6	116
GN 6322-10-7-C	10	7	10	M3	10	2.5	7	2.5	6	2.5	5
GN 6322-12-8-C	12	8	12	M4	12	3	8	2.5	8	3	8
GN 6322-16-12-C	16	12	16	M5	16	4	12	4.3	10	4	24
GN 6322-20-14-C	20	14	20	M5	20	5	14	5	10	5	45
GN 6322-22-16-C	22	16	22	M5	22	5.5	16	5	10	5.5	62
GN 6322-25-18-C	25	18	25	M5	25	6	18	5.6	10	6	90